



Product Line Industrial Filtration Technology

DFX

Industrial filters for extreme applications

Product Line Industrial Filtration Technology

Status: December 2012



Typical DFX Applications

Special Applications

- High Temperature
- Low Temperature
- Heavy Duty / Outdoor



Technical Gases

- Gas Manufacturing
- Gas Processing
- Gas Storage
- Gas Transportation
- Laboratory



Special Gases

- Natural gas / Biogas



DFX Application Specification

Housing Variant 1:

Compressed air for High / Low Temp. / Heavy Duty applications + Non-corrosive gases of Fluid Group 2

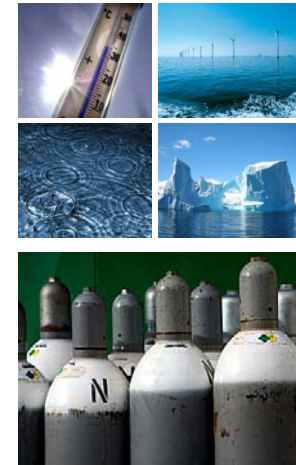

Medium	Air Nitrogen N ₂ Carbon Dioxide CO ₂ (dry) Helium He Argon Ar Neon Ne,
Operating pressure	≤ 25 bar
Operating temperature	-20°C...+100°C (wet conditions) -20°C...+120°C (dry conditions)
O-Ring material	Viton
Configuration	Plug on filter bowl

DFX Application Specification

Housing Variant 2:

Non-corrosive gases of Fluid Group 1
(ATEX on request)



Medium	Butane C ₄ H ₁₀ Carbon Monoxide CO Ethane C ₂ H ₆ Ethylene C ₂ H ₄ Hydrogen H ₂ Methane CH ₄ Natural Gas, dry Propane C ₃ H ₈ Propylene C ₃ H ₆ (on request)
Operating pressure	≤ 25 bar
Operating temperature	-20°C...+100°C (wet conditions) -20°C...+120°C (dry conditions)
O-Ring material	Viton
Configuration	Plug on filter bowl

DFX Housing Design

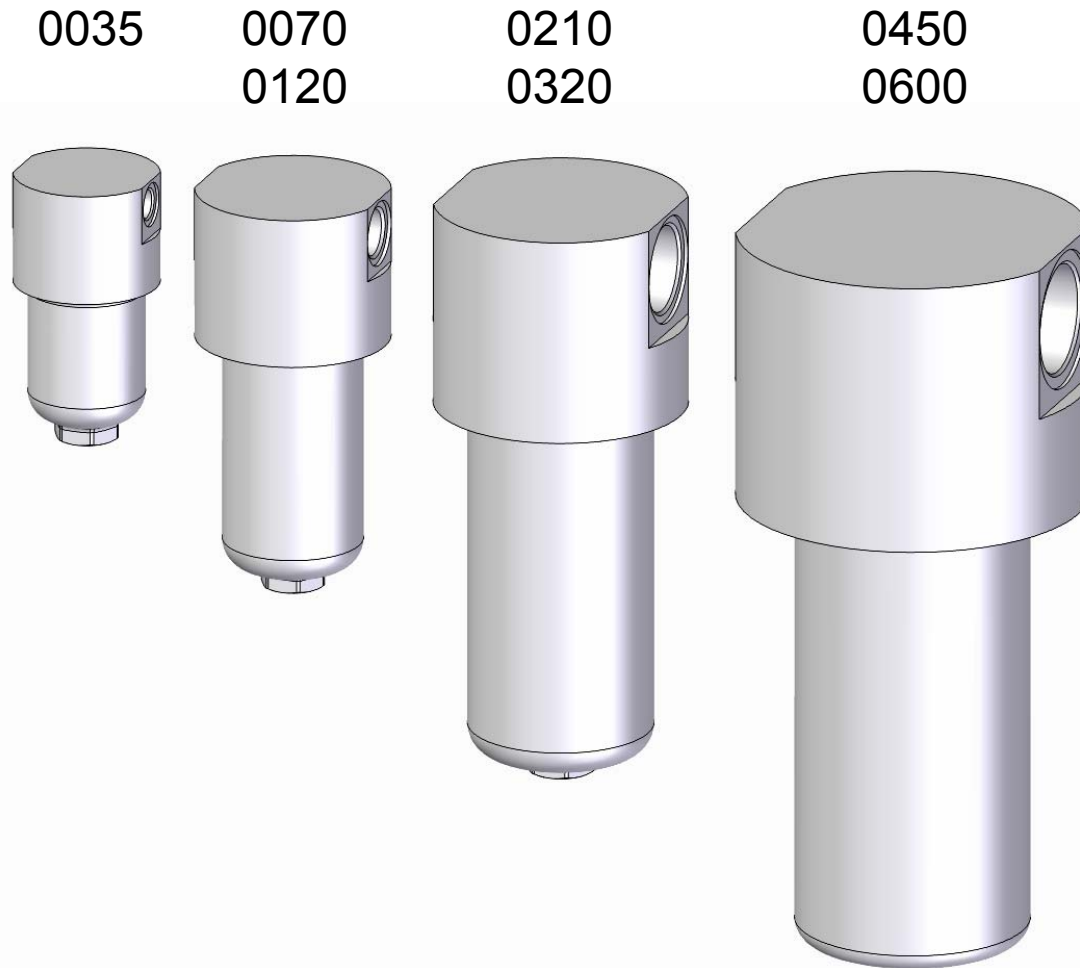

4 Basic housings for range of 7 filter types

DFX Housing Design

Dimensions + Weights

Type	G	Weight [kg] *)	Volume [l]	D	H	E	C	A
0035	3/8"	0,7	0,19	Ø75	144	67	Ø60	12
0070	1/2"	1,6	0,54	Ø100	212	90	Ø72	16,5
0120	3/4"	2,9	0,54	Ø100	217	90	Ø72	18,5
0210	1"	5,1	1,20	Ø120	296	108	Ø95	23
0320	1 1/2"	3,6	1,20	Ø130	310	113	Ø95	30
0450	1 1/2"	6,5	2,50	Ø160	383	146	Ø120	30
0600	2"	8,8	2,50	Ø180	396	161	Ø120	38

*) Weight without filter element

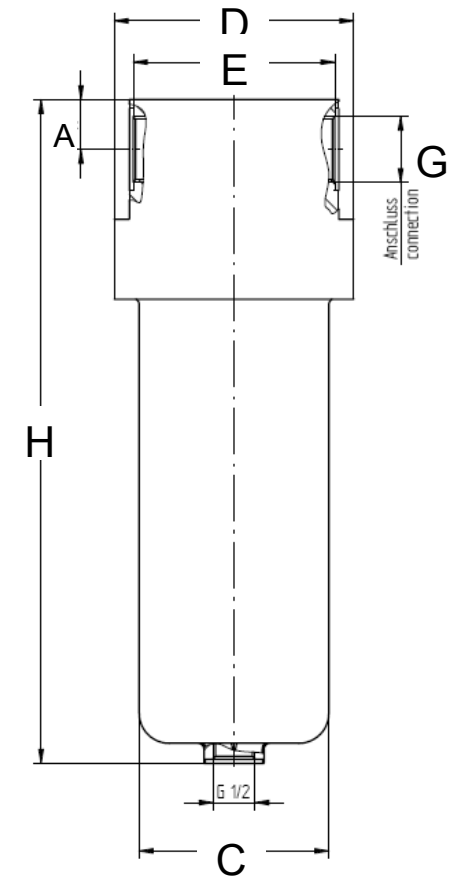

DFX Design

DFX housing based on HD-PN25 aluminum housing design

- Design pressure 25 bar
- Design temperature -20°C / +120°C
- Anodized aluminum surface
→ corrosion protection
- Leakage-proof concept with only 2 sealing points

New element / housing assembly concept

- Special groove supports installation and replacement of filter element
→ Element remains in filter bowl when housing is opened
→ Space-saving solution
- Push-in connection sealed with o-ring



DFX Design

Filter media and dimensions
concept taken from DF range

- Pre filter VX (wounded)
- Micro filter MX (pleated)
- Submicro filter SX (pleated)
- Activated carbon filter AX (wounded)
- Support of standardization
→ Less special solutions

Special end cap design

- Aftermarket support by end cap wings which fit into bowl grooves
- „Full metal“ design for high temperature + heavy duty applications



DFX Technical Data



Flow Capacity

Type	Connection	Nominal flow capacity ¹⁾ m ³ /h ²⁾
0035	3/8"	35
0070	1/2"	70
0120	3/4"	120
0210	1"	210
0320	1 1/2"	320
0450	1 1/2"	450
0600	2"	600

¹⁾ Nominal flow capacity related to 7 bar operating pressure

²⁾ Volume flow related to 1 bar (abs) / 20°C / compressed air application

DFX Filter Grades

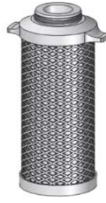
<p>Fine Filter</p>	 <p>VX</p>	<p>Particle retention: 100,0% (1,78–2,74µm) / 98,5% (1,16-1,78µm) / 83,1% (0,81-1,16µm) Oil retention (ISO12500-1): 96% Δp wet / dry: 120 mbar / 110 mbar</p>
<p>Micro Filter</p>	 <p>MX</p>	<p>Particle retention: 99,999% (0,36–0,52µm) / 99,955% (0,24-0,36µm) / 99,82% (0,19-0,24µm) Oil retention (ISO12500-1): 99,7% Δp wet / dry: 180 mbar / 110 mbar</p>
<p>Submicro Filter</p>	 <p>SX</p>	<p>Particle retention: 99,9997% (0,36–0,52µm) / 99,9996% (0,24-0,36µm) / 99,9997% (0,19-0,24µm) Oil retention (ISO12500-1): 99,8% Δp wet / dry: 365 mbar / 130 mbar</p>
<p>Oil Vapour Filter</p>	 <p>AX</p>	<p>Air Quality 8573-1:2010 Particles: Class 1 Oil: Class 1 (<0,003mg/m³) Δp dry: 130 mbar</p>

DFX Dimension Comparison

Competitor comparison of filter housing height

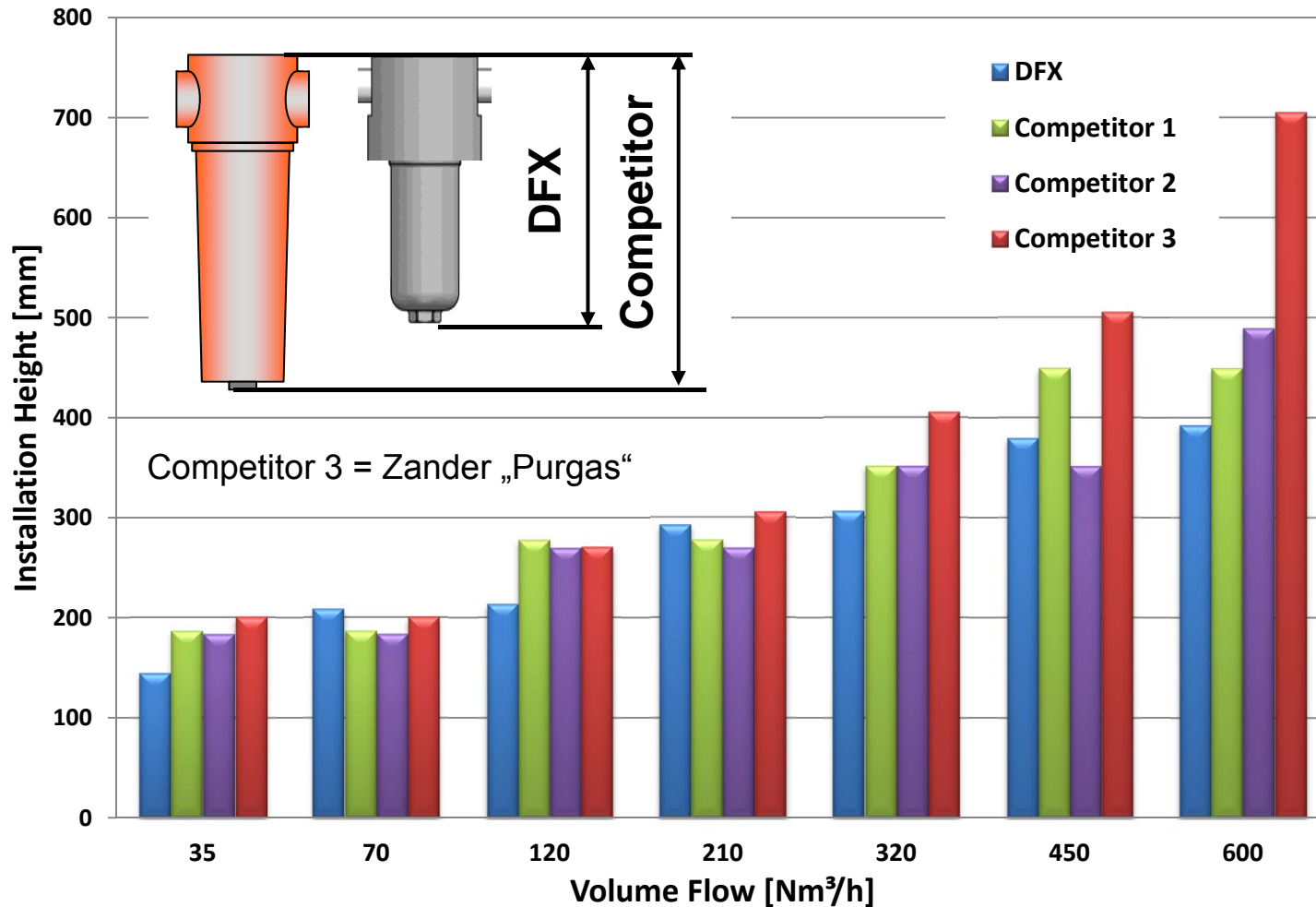

DFX housing height less than most of comparable competitor housings

DFX Dimension Comparison

Competitor comparison of total installation height

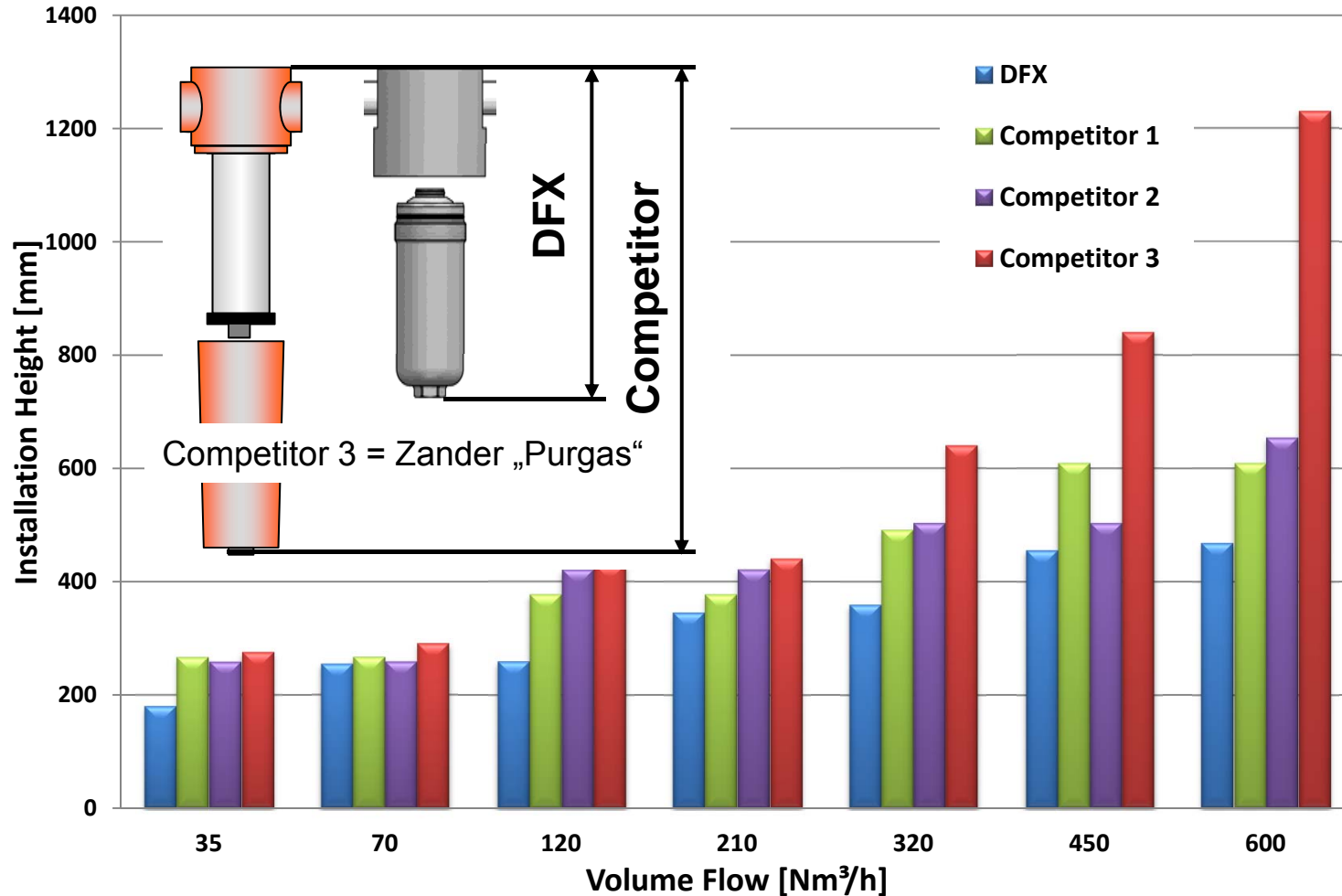

DFX housing concept saves up to ≈60% of total installation height (incl. space for element replacement)

DFX Sales Arguments

Similar high efficiency and filter performance than DF filter range

- Ensure highest purification and gas quality level in compressed air and technical gas applications
- Saving of energy cost due to low differential pressure



Leakage-proof „full-metal“ housing + element design

- High reliability in even challenging applications

High-quality housing material structure + surface

- Complete housing made of forge and machine process – no risk of bubbles (compared to cast metal housings)
- Smooth anodized surface ensures good corrosion protection
- No risk of particle release from housing surfaces

Unique element / housing connection (key + slot concept)

- Supports ease of element change
- Low space requirement for element change